

MASTS

Z 300 E

Z 300 E 7/8

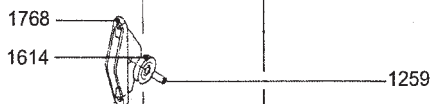
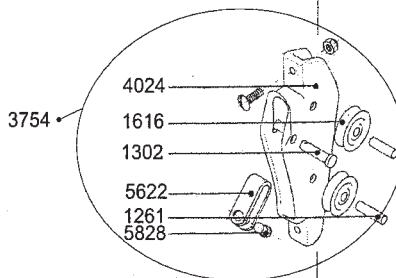
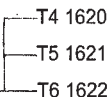
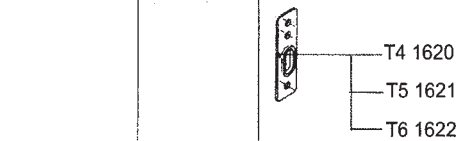
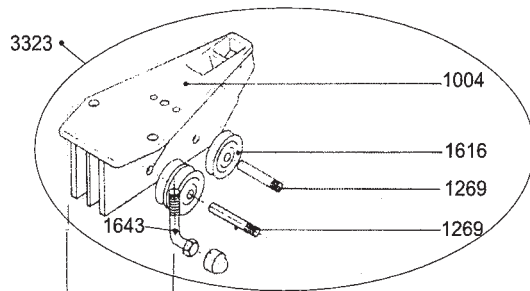
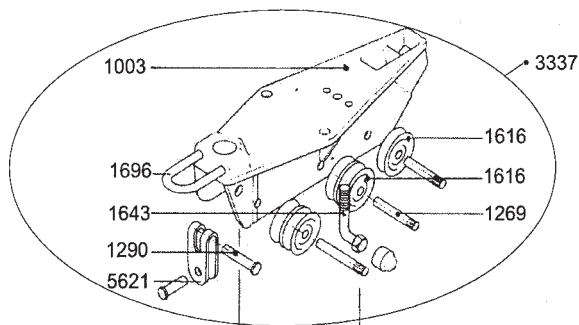

- 0° 5095
- 5° 5088
- 10° 5089
- 15° 5090
- 20° 5091
- 25° 5093
- 30° 5092

- 0° - 15° 5096
- 20° - 30° 5085

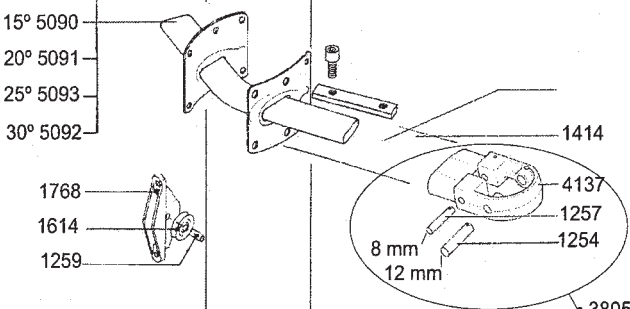
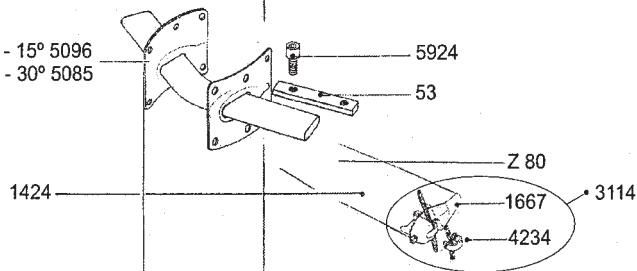

1241
Stainless Steel

1291
1241
Stainless Steel

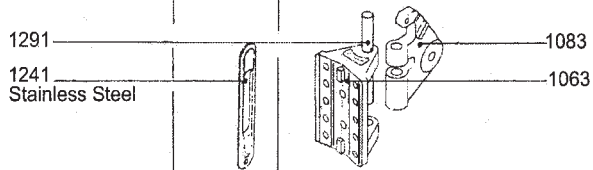
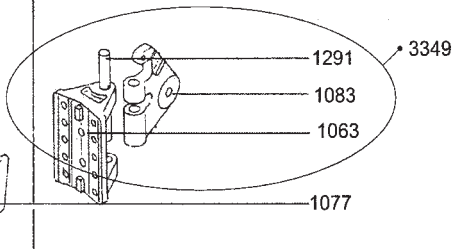
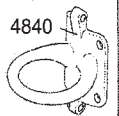

1081 Metal
4586 Plastic

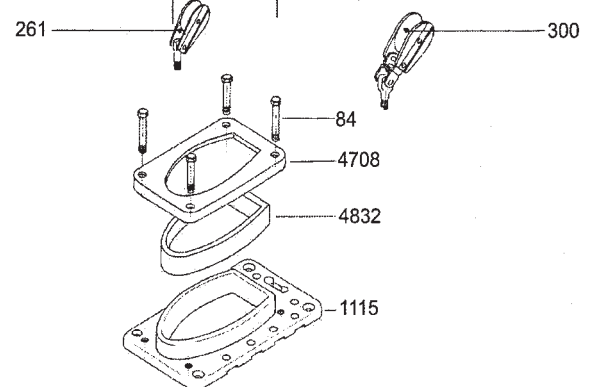
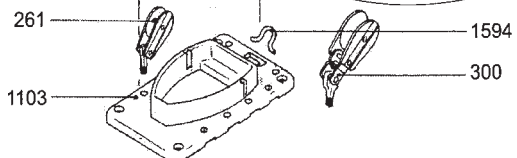
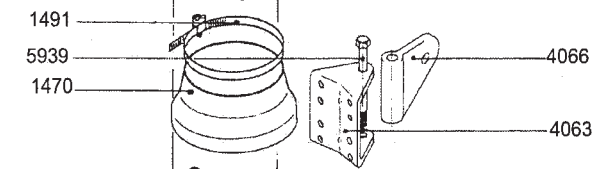
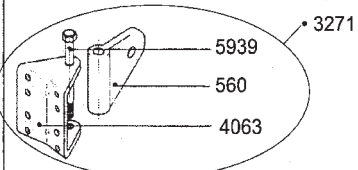

FURLING MASTS

Z 400 E

Z 400 E 7/8

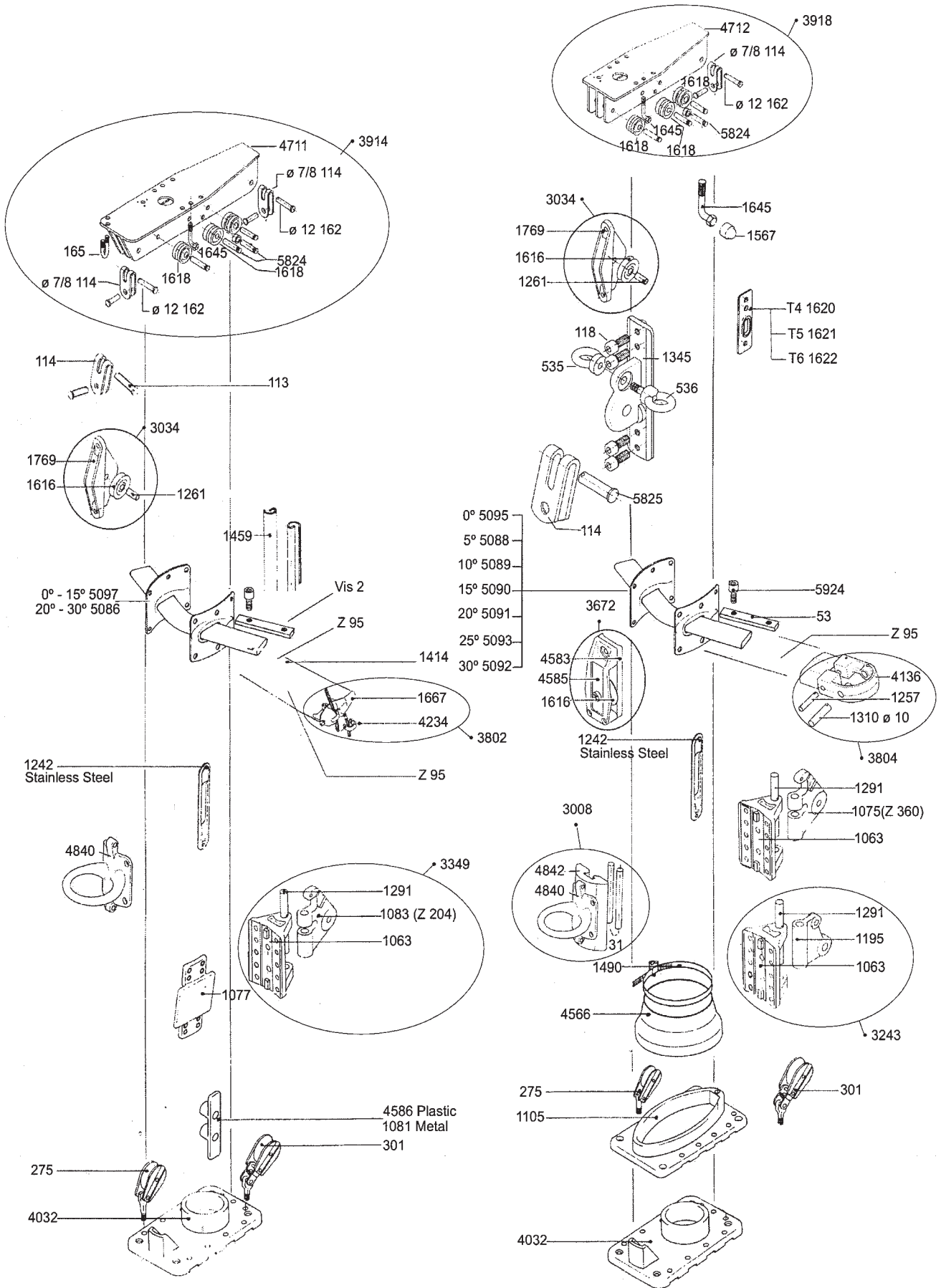

FURLING MASTS

Z 500 E

Z 500 E 7/8

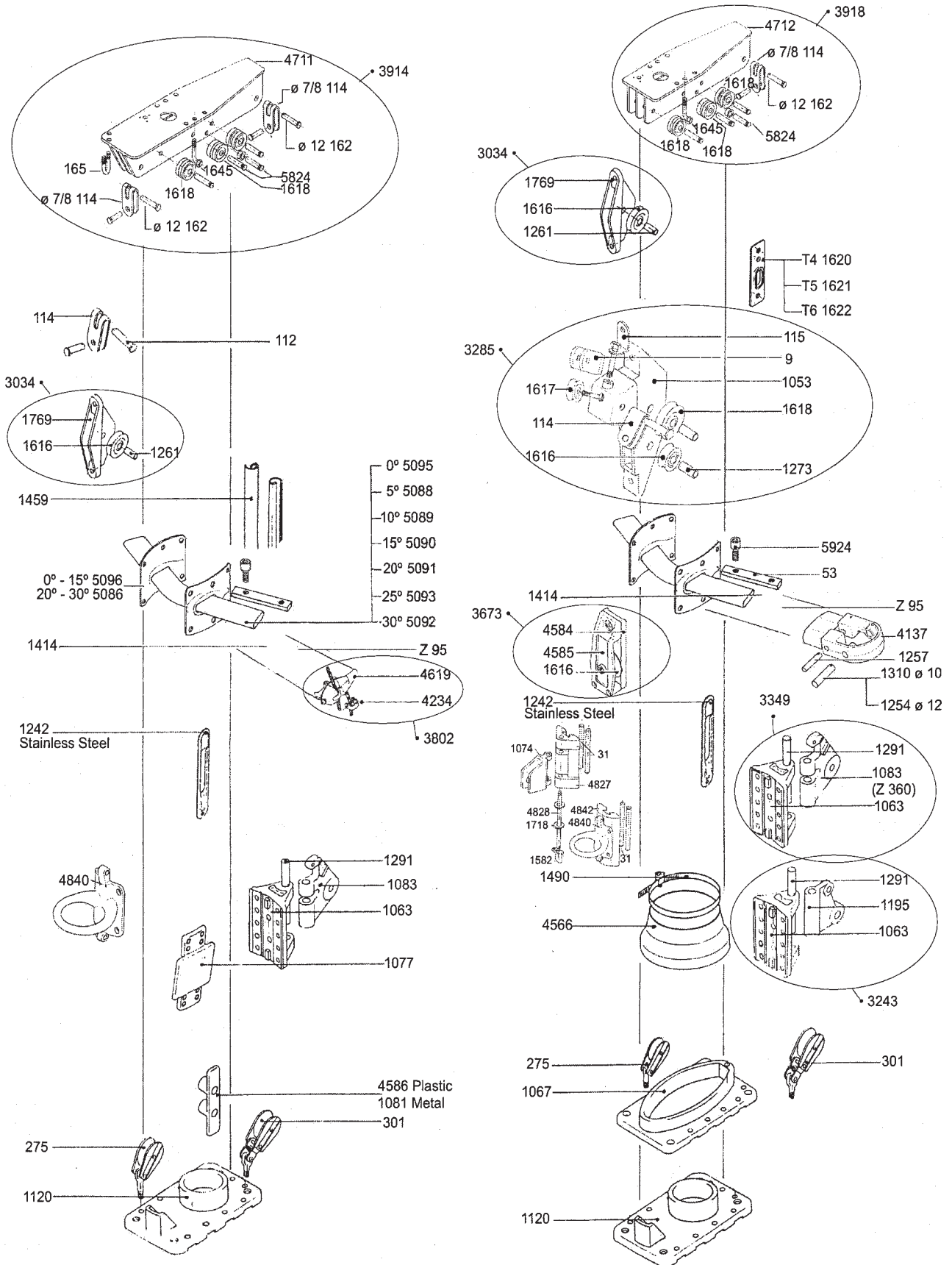

FURLING MASTS

Z 600 E 7/8

Z 600 E

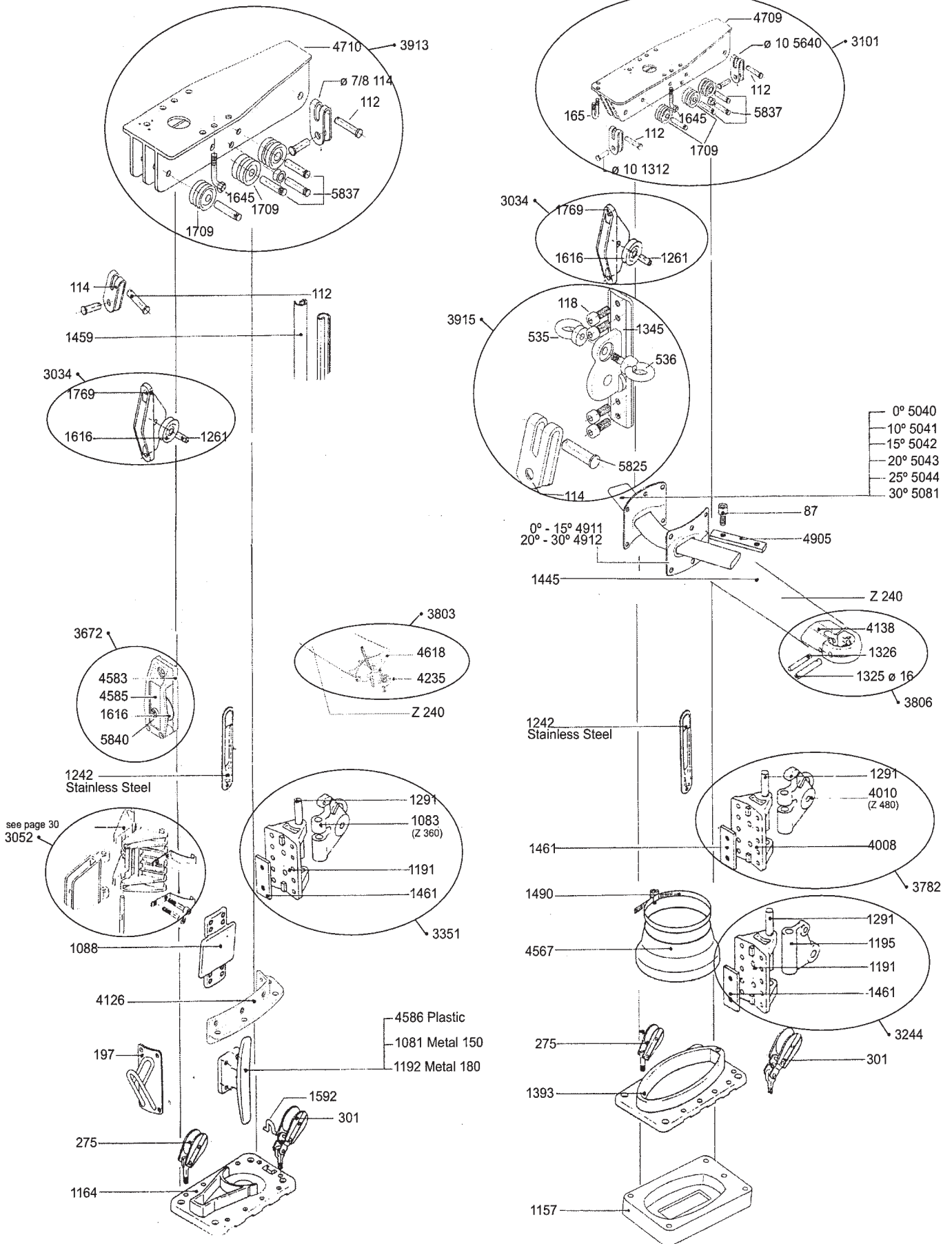

FURLING MAST

Z 700 E

Z 700 E 7/8

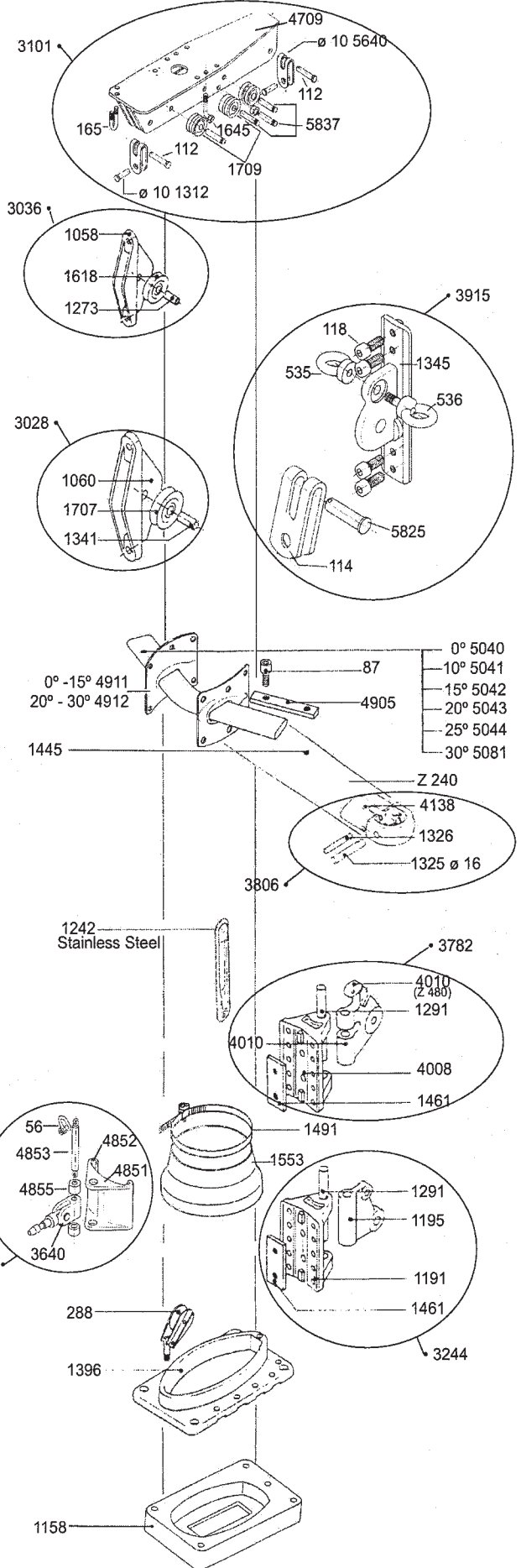
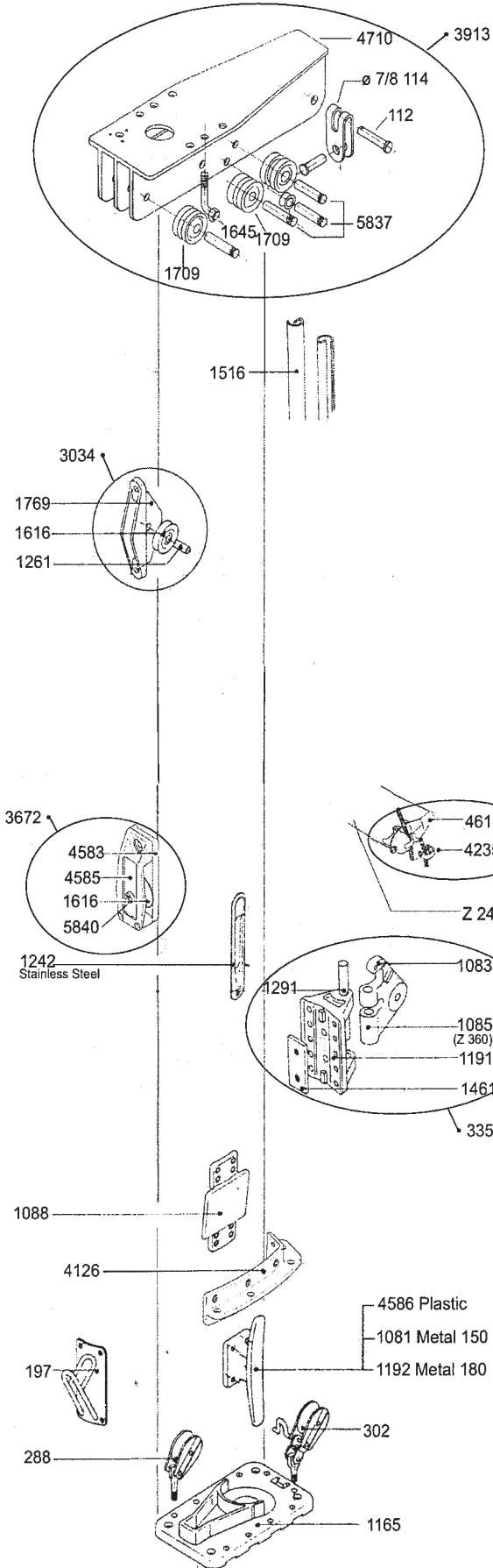

FURLING MASTS

Z 900 E

Z 900 7/8

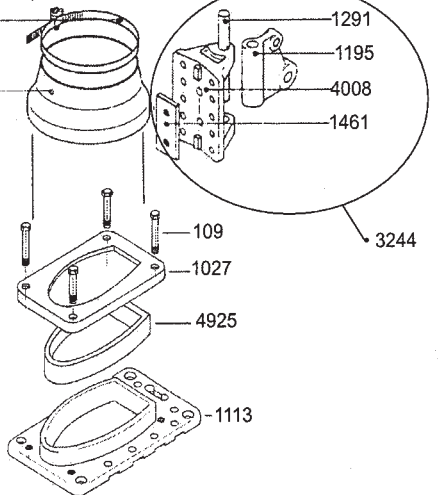
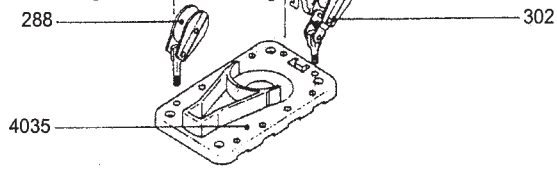
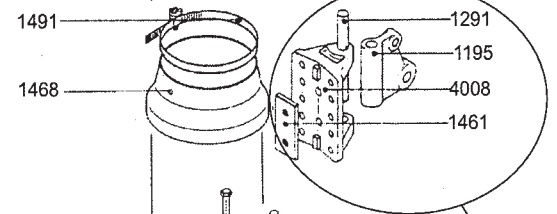
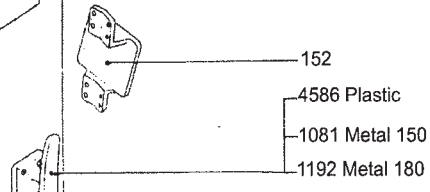
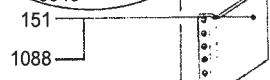
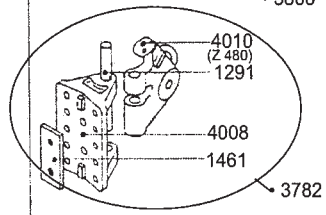
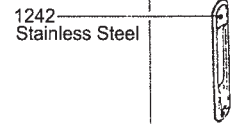
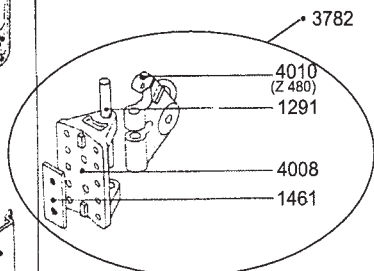
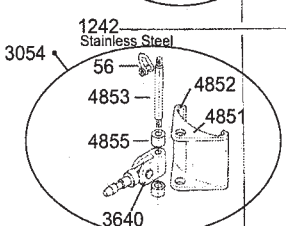
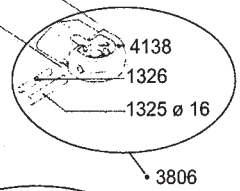
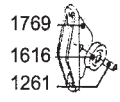
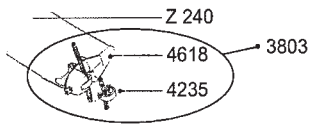
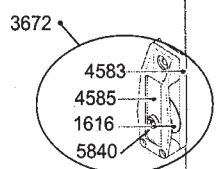
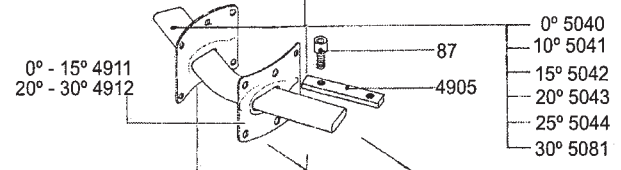
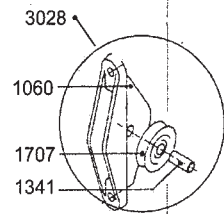
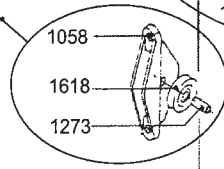
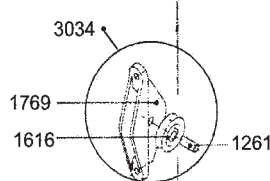
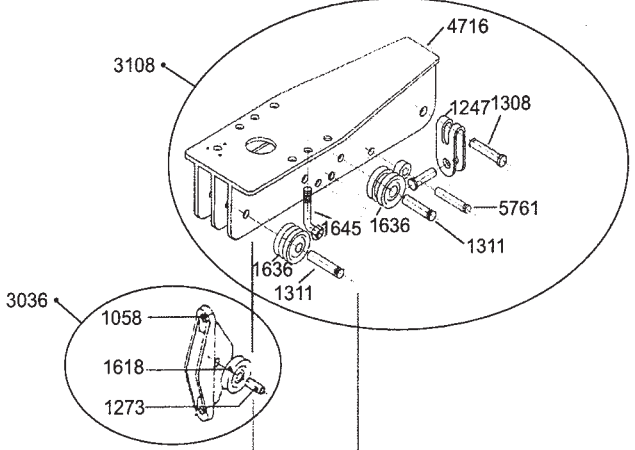
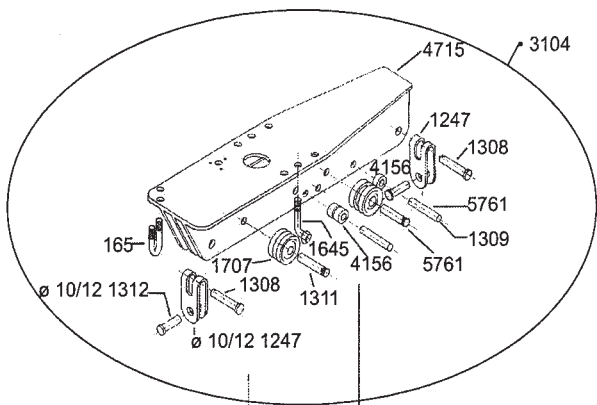

FURLING MASTS

Z 1100 E

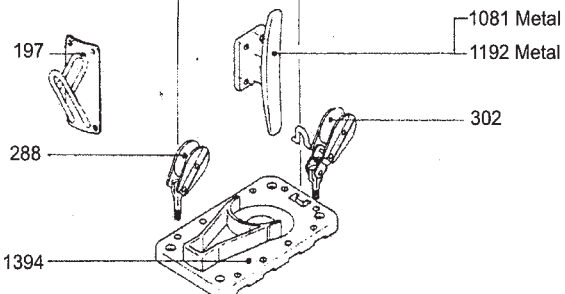
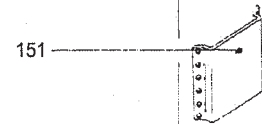
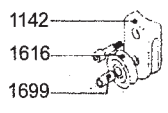
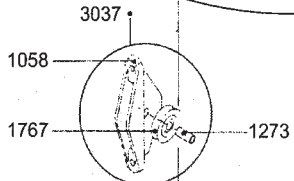
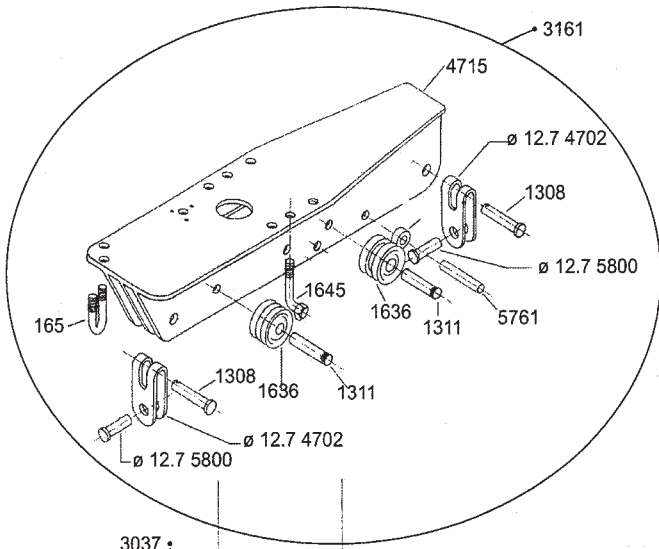

Z 1100 E 7/8

